

8000 | 8300 Series Electric Strikes



ASSA ABLOY

Experience a safer
and more open world

Installation Instructions

Product Components

- A 8000 | 8300 Electric Strike Body
- B Sticky Shims (optional use)
- C 12 & 24 Volt Plug In Connectors

Electrical Specifications

Electrical Ratings for Solenoid	Continuous Duty		Intermittent Duty*		
	12 VDC	24 VDC	12 VAC	16 VAC	24 VAC
Voltage	12 VDC	24 VDC	12 VAC	16 VAC	24 VAC
Resistance in Ohms	50	200	50	50	200
Amps	.24	.12	.24	.32	.12

Solenoids are rated at +/- 10% indicated value.
*10% max duty cycle (2 min. max on time)

Shall be powered by a UL 294 Class 2 Power Limited power supply or Listed Access Control units or ULC-60839-11-1: Grade 1 listed Access Control Units.

For inductive kickback protection, consider using with the HES 2005M3 SMART Pac® III or 2001M Plug-in Bridge Rectifier with built-in MOV (not evaluated by UL294/UL1034).

Minimum Wire Gauge Requirements		
Voltage	12 VDC	24 VDC
200 feet or less	18 gauge	20 gauge
200–300 feet	16 gauge	18 gauge
300–400 feet	14 gauge	16 gauge

Lengths based on round trip. The minimum permissible wire size to be used shall not be less than 26 AWG. Wiring methods shall be in accordance with the National Electrical Code (ANSI/NFPA70), local codes and the authorities having jurisdiction.

UL1034 Performance Levels	
Static Strength	1,500 lbs
Dynamic Impact	70 ft-lbs
Endurance	250,000 cycles

Suitable for outdoor use.

UL294 Performance Levels*	
Destructive Attack	Level I (No attack test)
Line Security	Level I (No line security)
Endurance	Level IV (100,000 cycles)
Standby Power	Level I (No secondary power source)

*Monitor options were not evaluated to UL294/UL1034/
ULC-60839-11-1: Grade 1. Indoor use.

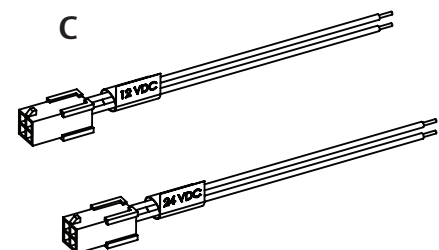
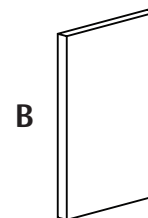
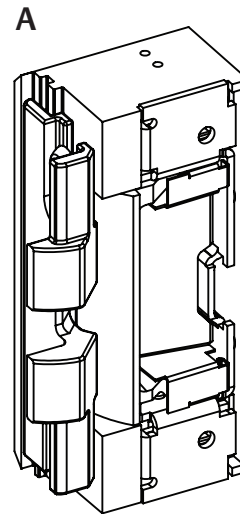

Installation



WARNING: Before connecting any device at the installation site, verify input voltage using a multimeter. Many power supplies and low voltage transformers operate at higher levels than listed. Any input voltage exceeding 10% of the solenoid rating may cause severe damage to the unit. Installation wiring for the product and wiring methods shall be in accordance with the National Electrical Code, ANSI/NFPA 70.

Preparing the Strike

For 12 VAC, 12 VDC, or 16 VAC, the Plug In Connector (pigtail) marked "12 VDC" should be used; for 24VAC or 24 VDC, the pigtail marked "24 VDC" should be used.

- 1 SELECT the appropriate plug in connector that matches system power and electrically CONNECT as shown in **Diagram 1**, "12 VDC to 24 VDC Conversion."

NOTE: BLACK wire of pigtail is NEGATIVE (-).

- 2 IF using optional Latchbolt Monitor (LBM) THEN COMPLETE wiring in accordance with **Table 1**, "Wiring (Monitored Version)".
- 3 VERIFY that the strike is in the correct mode of operation (Fail Secure or Fail Safe).
- 4 IF the 8000|8300 Series Electric Strike must be converted to Fail Safe mode, THEN CONVERT in accordance with **Diagram 2**, "Fail Safe Conversion".

Preparing the Frame

- 1 PREPARE the frame for lockset using appropriate cutout template, as shown (see page 4).

Finishing the Installation

- 1 CHOOSE the appropriate faceplate for the strike as shown (see page 4).
- 2 INSTALL faceplate on strike using 2X #8-32 x 1/2" flat head screws.
- 3 CONNECT wires from the power source to the strike.
- 4 INSTALL the electric strike unit in jamb cutout, using 2X #12-24 x 1/2" Mounting Screws provided with the faceplate (or wood screws where necessary).
- 5 IF vertical adjustment is needed, THEN GO TO "Adjusting the Vertical Position" section (see page 3).

Wiring (Monitored Version)

Table 1: Latchbolt Monitor (LBM)

White	Common
Orange	Normally Open
Green	Normally Closed

NOTE: State as shown when door is open.

Diagram 1:
12 VDC to 24 VDC Conversion

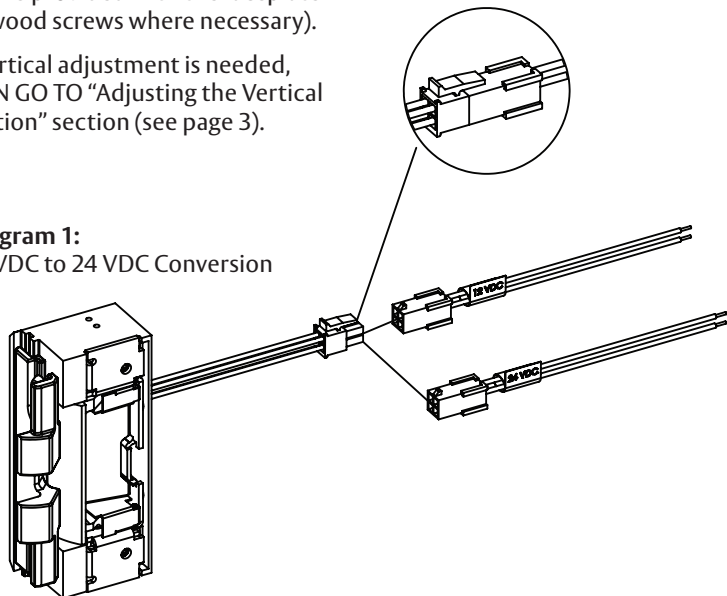

Diagram 1a:
Fail Secure LBM Wiring Example

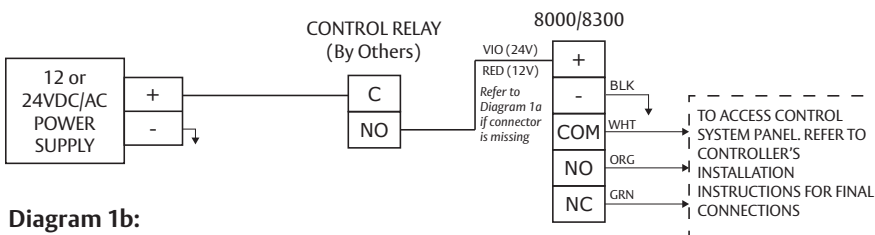

Diagram 1b:
Fail Safe Wiring Example

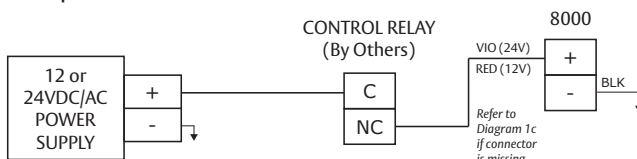
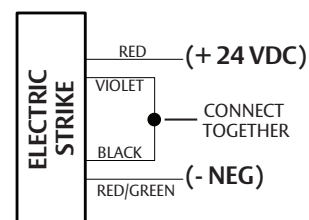
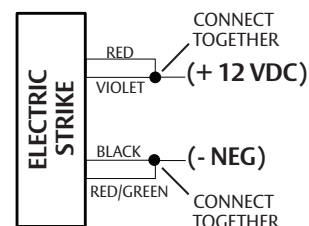

Diagram 1c:
If Connector is Missing



Converting the Operation Mode

This unit ships in Fail Secure mode. To convert to Fail Safe mode, perform the following instructions.

The system shall not be installed in the fail-secure mode unless permitted by local authority having jurisdiction and shall not interfere with the operation of Listed panic hardware.

- 1 LOOSEN the two #2-56 screws located on the back of the strike but DO NOT REMOVE them.
- 2 MOVE screws from the top of the hole (Fail Secure mode position) to the bottom of the hole (Fail Safe mode position) as shown in **Diagram 2**.
- 3 TIGHTEN the bottom screw first (wire side), and THEN TIGHTEN the top screw.
- 4 VERIFY the strike is now in the Fail Safe operation mode.
- 5 IF the strike still operates as Fail Secure, THEN ENSURE the screws are fully seated in the top position.

NOTE: Fire rating only applies to Fail Secure Units. Conversion to Fail Safe negates fire rating on 8300.

Diagram 2: Fail Safe Conversion

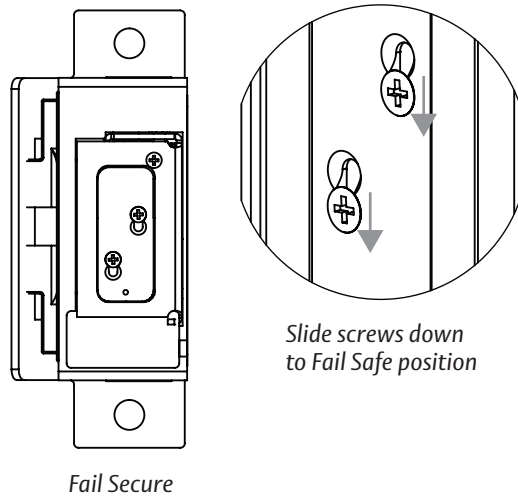
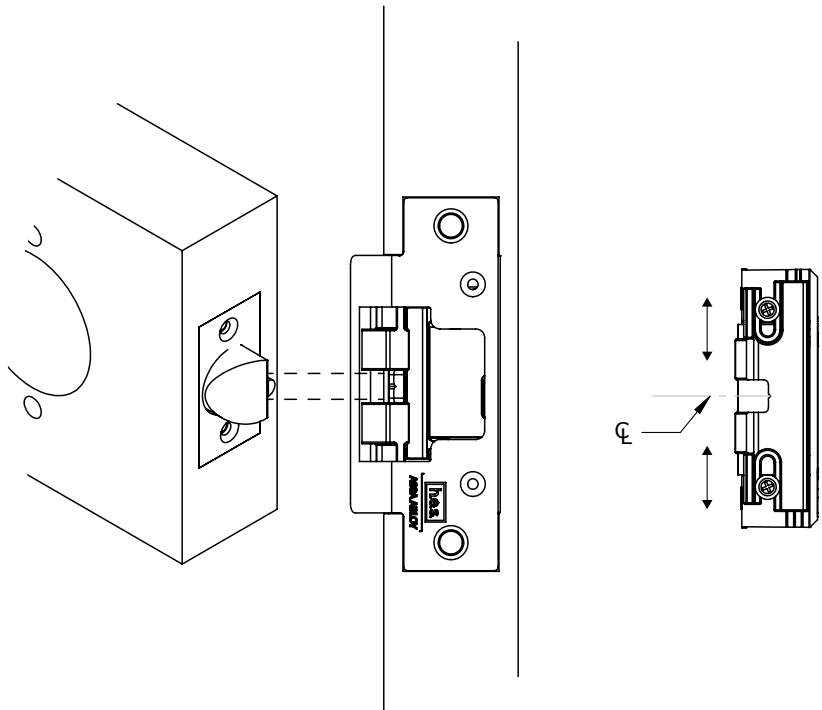

Diagram 3: Vertical Adjustment



Adjusting the Vertical Position

NOTE: The deadlatch must not interfere with the 8000/8300 ramps, see **Diagram 3**.

- 1 MARK the centerline of the deadlatch onto the 8000/8300 faceplate.
- 2 REMOVE the 8000/8300 electric strike from jamb.
- 3 LOOSEN the screws and SLIDE internal ramp until the groove between the ramps aligns with the mark made on the faceplate.
- 4 TIGHTEN the screws.

Evaluation and Troubleshooting Guide

Evaluate the Opening

Introduction

The 8000/8300 electric strike is designed to work with an **unmodified, plumb and square** door frame. It uses internal ramps to release the latchbolt. Proper alignment is crucial for functionality.

NOTE: Ensure a minimum 1/8" gap between door and frame.

1 STEP 1

VERIFY Door and Frame Alignment (Diagram 4).

CHECK for Frame Twist: The angle between the closed door face and the inner frame face (rabbet) should ideally be 90 degrees (and no more than 95).

PLACE a carpenter's square against the door stop and the door face.

INSTALL shims if the angle is less than 90 degrees (see Step 3).

Diagram 4: Door and Frame Alignment

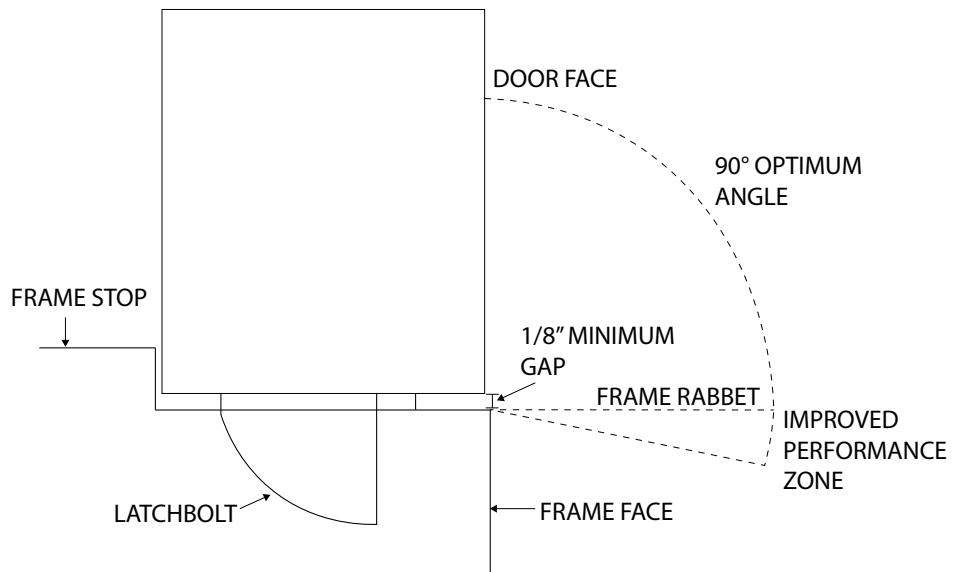

2 STEP 2

TEST Latchbolt Condition (Diagram 5).

APPLY slight pressure to the latchbolt tip at a 45-degree angle to the door face. The latchbolt should retract smoothly into the door.

NOTE: If the latchbolt is damaged or doesn't move smoothly, the strike may not function properly. Contact latchbolt manufacturer. As the door opens, the deadlatch will drop allowing the latchbolt to slide along the internal ramps and fully release.

Diagram 5: Latchbolt Condition

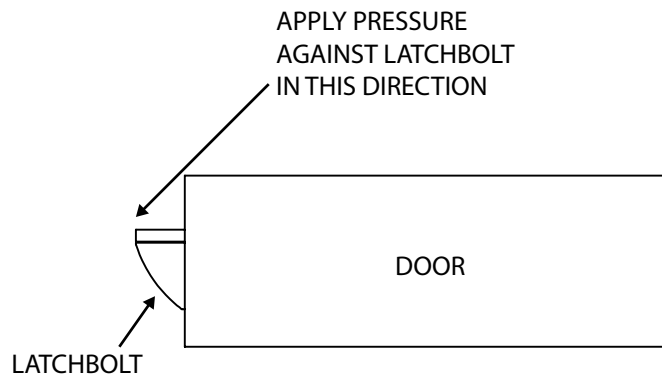

Shim Installation

3 STEP 3

INSTALL Sticky Shims (If Necessary)

Shim Installation RECOMMENDED (Option 1—Frame): PLACE shims under the top and bottom (stop side) of the electric strike's faceplate (Diagram 6).

Shim Installation (Option 2—Door): ALTERNATIVELY, place shims under the top and bottom (bevel side) of the latchbolt (Diagram 7).

NOTE: Shims compensate for frame twist or adjust the angle of the latch relative to the internal ramps of the strike to the optimal 40-45 degrees, ensuring proper latchbolt release (Diagram 8).

4 STEP 4

MOUNT the Electric Strike

INSTALL the 8000/8300 electric strike into the door frame.

ALIGN the deadlatch to pass between the two internal ramps without contacting either ramp (Diagram 3).

5 STEP 5

TEST Operation

When energized, the keeper should release the latchbolt.

As the door opens, the deadlatch will drop allowing the latchbolt to slide along the internal ramps and fully release.

Diagram 6: Shim Installation—Frame

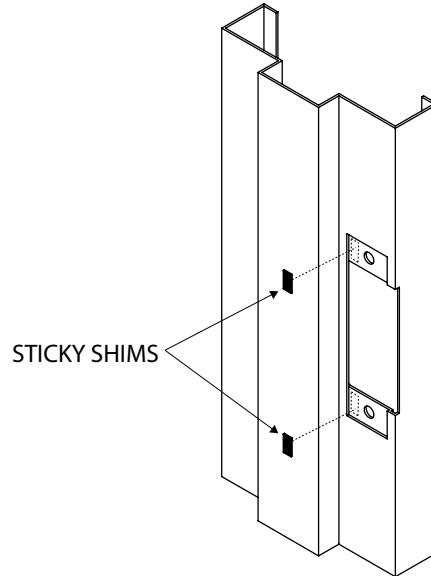

Diagram 7: Shim Installation—Door

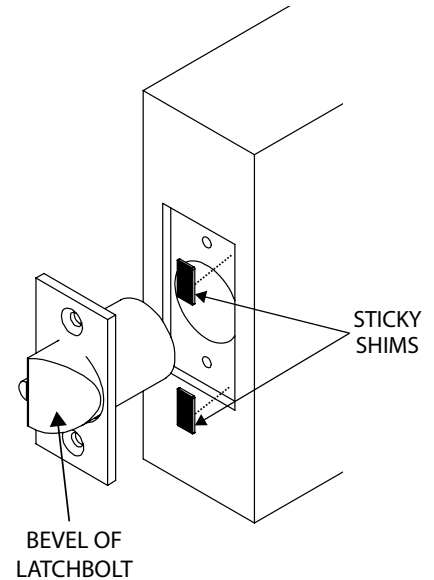
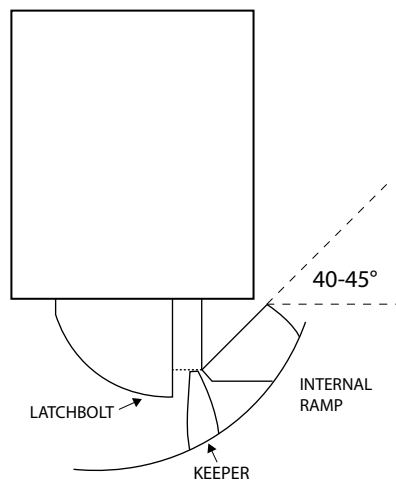

Diagram 8: Door Opening



Cutout Templates for Frame Preparation

Inches [Millimeters]

801 Faceplate Option

(4-7/8" x 1-1/4"), Square Corners; Used with cylindrical locksets in ANSI metal jambs.

NOTE: The 8000/8300 electric strike with 801 faceplate will fit right into most standard ANSI A115.2, 1" deep dustboxes requiring no cutting. If you elect to place the 8000/8300 into the existing dustbox, simply drill for wire connections.

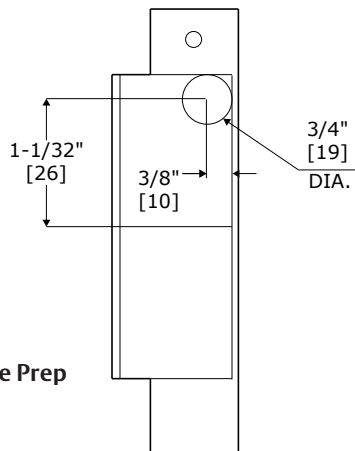
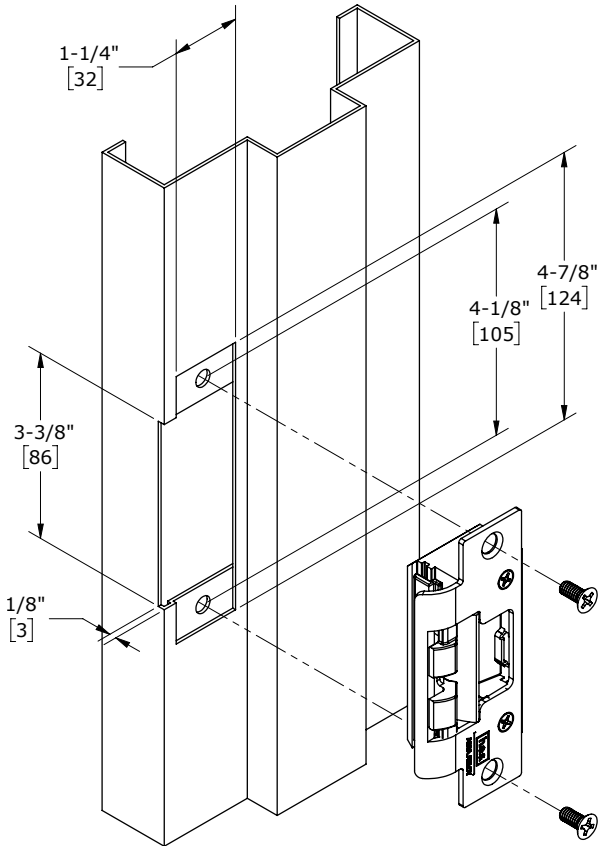

Dustbox Wire Prep

801-801E Comparison

NOTE: Prep templates assume standard 1-3/4" thick door and frame rabbet. For frames with extra snap-on trim or casing, consider the 801E instead.

Difference between referenced dimensions is 5/32".

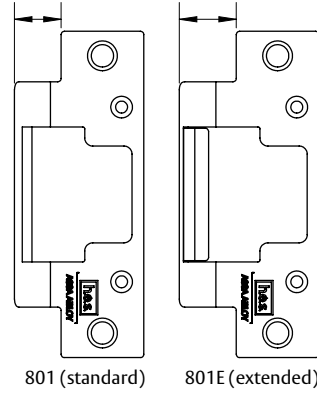

801A Faceplate Option

(4-7/8" x 1-1/4"), Radius Corners; Used with cylindrical locksets in Aluminum frames.

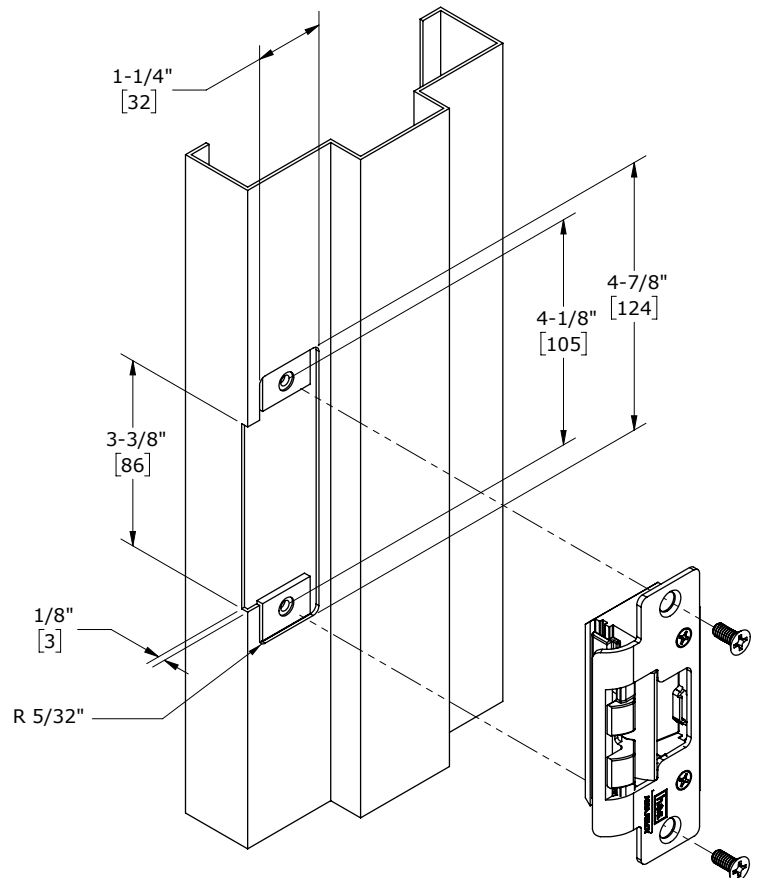

Cutout Templates for Frame Preparation *(continued)*

Inches [Millimeters]

802 Faceplate Option

(7-15/16" x 1-7/16"), Radius Corners; Used with cylindrical locksets in Aluminum frames.

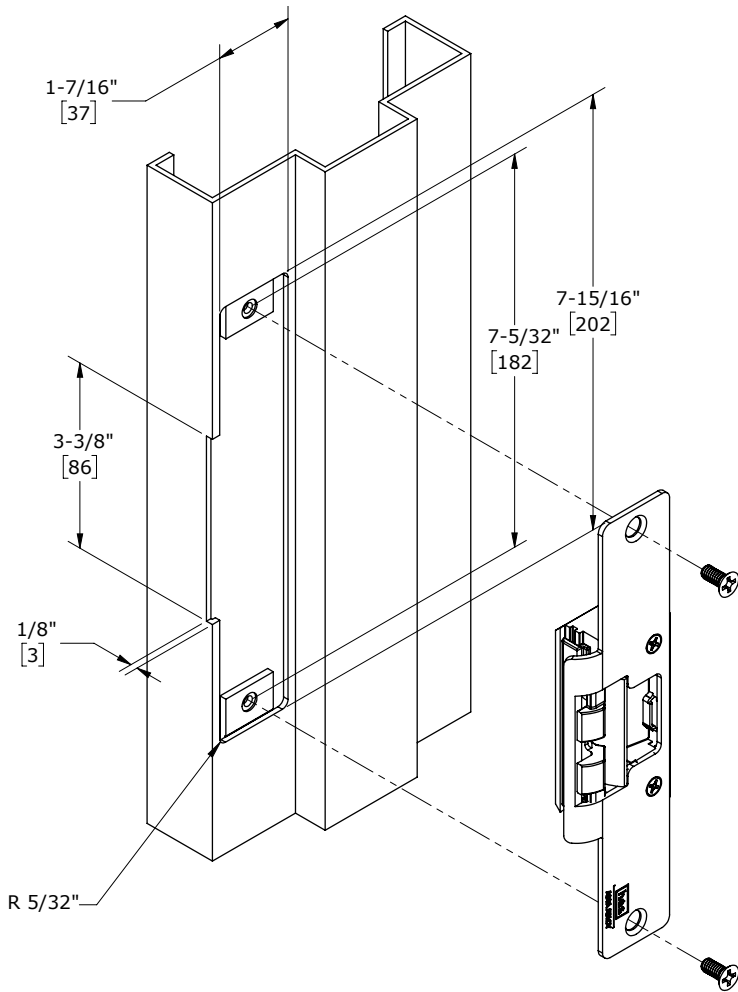

803 Faceplate Option

(6-7/8" x 1-1/4"), Radius Corners; Used with cylindrical locksets in Aluminum frames.

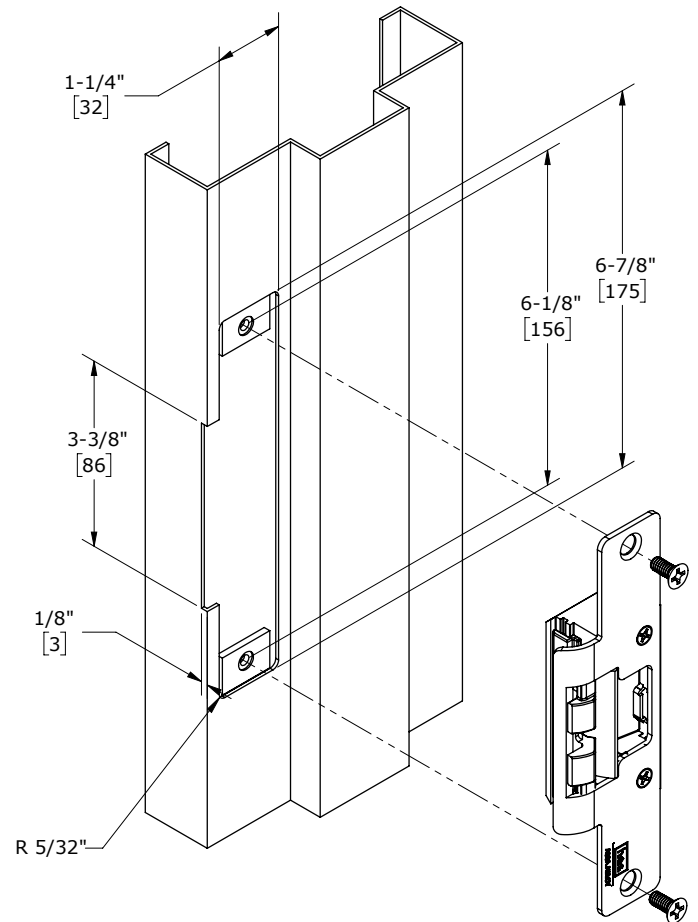

Cutout Templates for Frame Preparation *(continued)*

Inches [Millimeters]

805 Faceplate Option

(9" x 1-3/8"), Radius Corners and Flat Faceplate; Used with cylindrical locksets. Four-point mounting for wood installations. Remove additional material as needed to provide clearance for electric strike and wires. Then drill for wires.

NOTE: Faceplate can be used as a template to drill pilot holes after the frame has been prepped for electric strike.

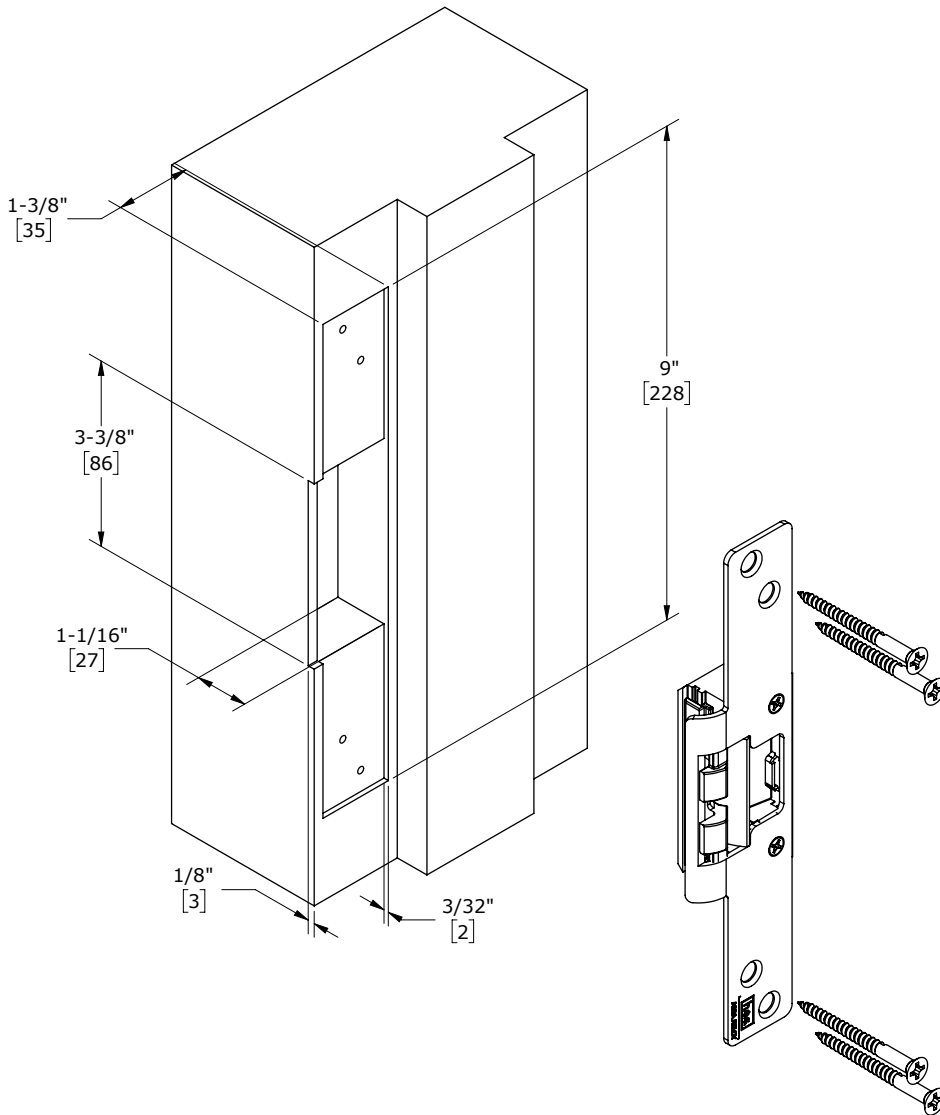

Warranty For information on warranty coverage and replacement options, please visit [hesinnovations.com/warranty](https://www.hesinnovations.com/warranty)



techsupport.hes@assaabloy.com
hesinnovations.com | 800 626 7590

Printed in the U.S.A.
Patent pending and/or patent www.assaabloydss.com/patents
Copyright © 2025, Hanchett Entry Systems, Inc., an ASSA ABLOY Group company.
All rights reserved. Reproduction in whole or in part without the express written permission of Hanchett Entry Systems, Inc. is prohibited. 3068006.003_6